

SKETCH/AREA TABLE ADDENDUM

File No 3005410

SUBJECT

Property Address	30-38-10-00-20.A		
City	County	Brevard	State FL Zip
Owner			
Client	Client Address 5387 Bannock Street		
Appraiser Name	David Smith	Inspection Date	Titusville

IMPROVEMENTS SKETCH

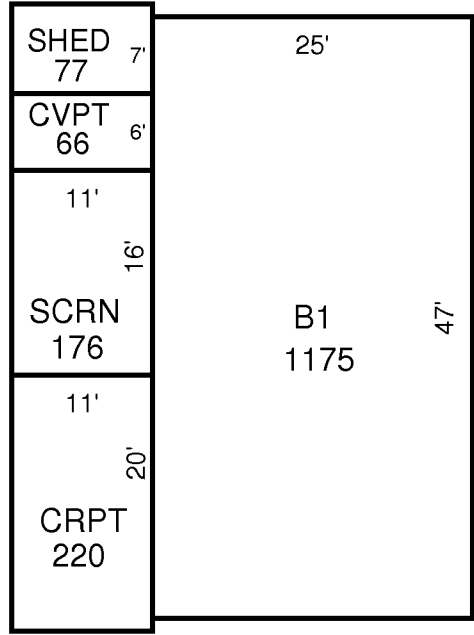

AREA CALCULATIONS

AREA CALCULATIONS SUMMARY					
Code	Description	Factor	Net Size	Perimeter	Net Totals
B1	B1	1.00	1175	144	1175
CP	CRPT	1.00	220	62	220
SHED	SHED	1.00	77	36	77
SCRN	SCRN	1.00	176	54	176
CVPRT	CVPT	1.00	66	34	66

Comment Table 1	
Comment Table 2	Comment Table 3