

# SKETCH/AREA TABLE ADDENDUM

File No 3005245

SUBJECT

Property Address <b>30-38-10-00-13.Y</b>			
City	County <b>Brevard</b>	State <b>FL</b>	Zip
Owner			
Client	Client Address <b>7620 Boxelder</b>		
Appraiser Name <b>David Smith</b>	Inspection Date <b>Titusville</b>		

IMPROVEMENTS SKETCH

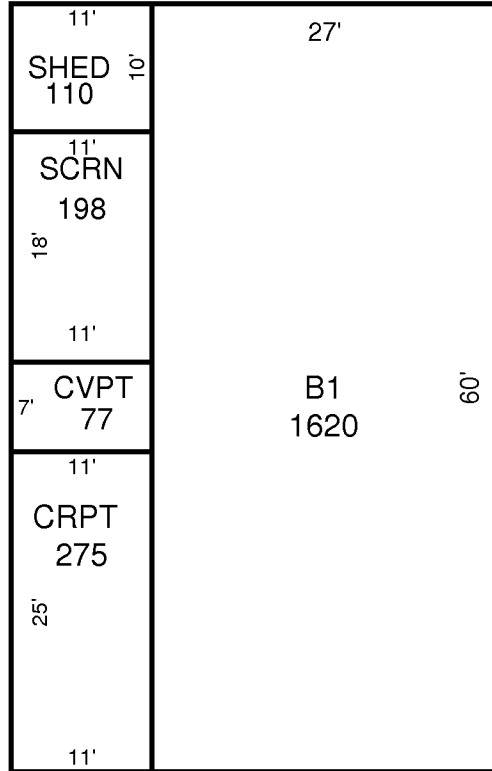

AREA CALCULATIONS

AREA CALCULATIONS SUMMARY					
Code	Description	Factor	Net Size	Perimeter	Net Totals
B1	B1	1.00	1620	174	1620
SP	SCRN	1.00	198	58	198
CP	CRPT	1.00	275	72	275
SHED	SHED	1.00	110	42	110
CVPRT	CVPT	1.00	77	36	77

Comment Table 1	
Comment Table 2	Comment Table 3