

SKETCH/AREA TABLE ADDENDUM

File No 3005195

SUBJECT

Property Address	30-38-10-00-12.B		
City	County	Brevard	State FL Zip
Owner			
Client	Client Address	7603 Boxelder	
Appraiser Name	David Smith	Inspection Date	Titusville

IMPROVEMENTS SKETCH

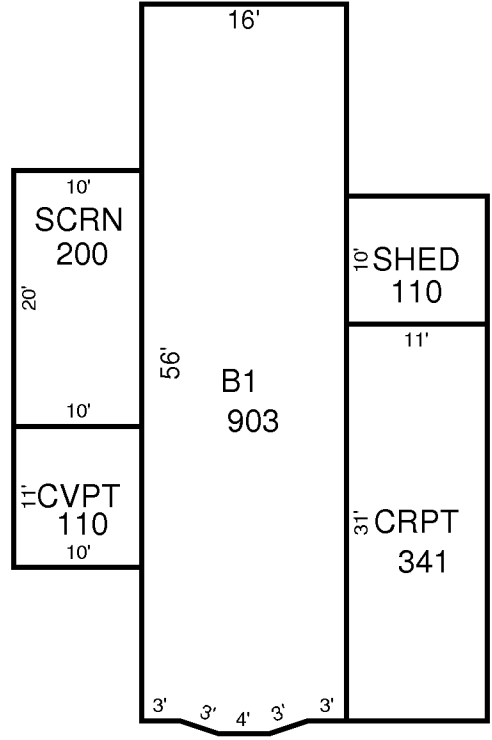

AREA CALCULATIONS

AREA CALCULATIONS SUMMARY					
Code	Description	Factor	Net Size	Perimeter	Net Totals
B1	B1	1.00	903	144	903
SP	SCRN	1.00	200	60	200
CP	CRPT	1.00	341	84	341
SHED	SHED	1.00	110	42	110
CVPT	CVPT	1.00	110	42	110

Comment Table 1	
Comment Table 2	Comment Table 3