

SKETCH/AREA TABLE ADDENDUM

File No 2962258

SUBJECT

Property Address	29-37-19-51- -80		
City	Palm Bay	County	Brevard
		State	FL
Zip			
Owner			
Client	Client Address 312 BRANDY CREEK CIR. SE		
Appraiser Name	AEC	Inspection Date	PALM BAY

IMPROVEMENTS SKETCH

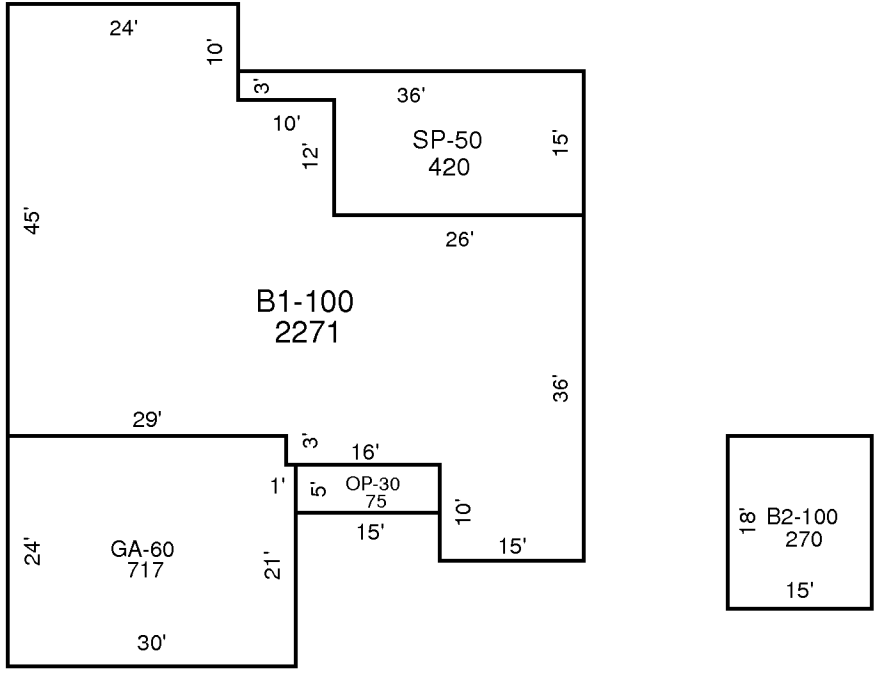

AREA CALCULATIONS

AREA CALCULATIONS SUMMARY					
Code	Description	Factor	Net Size	Perimeter	Net Totals
B1	B1-100	1.00	2271	236	2271
B2	B2-100	1.00	270	66	270
GA7	GA-60	1.00	717	108	717
OP4	OP-30	1.00	75	40	75
SP6	SP-50	1.00	420	102	420

Comment Table 1	
Comment Table 2	Comment Table 3