

SKETCH/AREA TABLE ADDENDUM

File No 2960877

Property Address 29-37-20-RP- -44	County Brevard	State FL	Zip 32909
City PALM BAY			
Owner			
Client	Client Address 1923 WINDBROOK DR SE		
Appraiser Name Wayne Ingram	Inspection Date Palm Bay		

SUBJECT

IMPROVEMENTS SKETCH

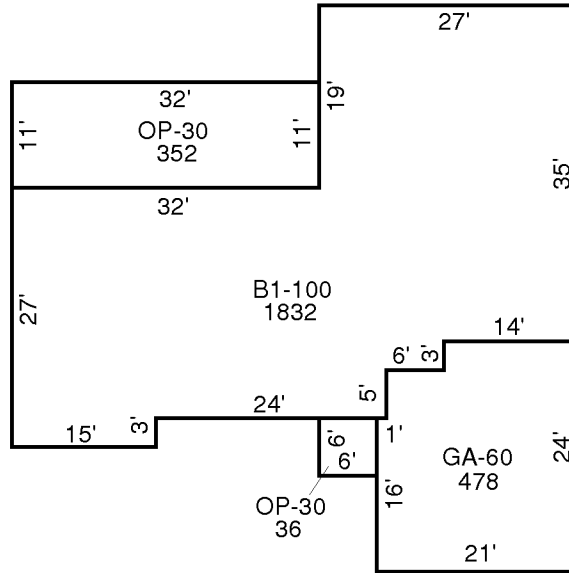

AREA CALCULATIONS

AREA CALCULATIONS SUMMARY					
Code	Description	Factor	Net Size	Perimeter	Net Totals
B1	B1-100	1.00	1832	210	1832
GA7	GA-60	1.00	478	90	478
OP4	OP-30	1.00	36	24	
	OP-30	1.00	352	86	388

Comment Table 1	
Comment Table 2	Comment Table 3