

SKETCH/AREA TABLE ADDENDUM

File No 2953224

SUBJECT

Property Address 29-38-03-50-C-16

City County BREVARD State FL Zip

Owner SFR 1-16-04 MO154809 \$125,000

Client Client Address 350 RIGGS AVENUE

Appraiser Name Paul Knob Inspection Date Palm Bay

IMPROVEMENTS SKETCH

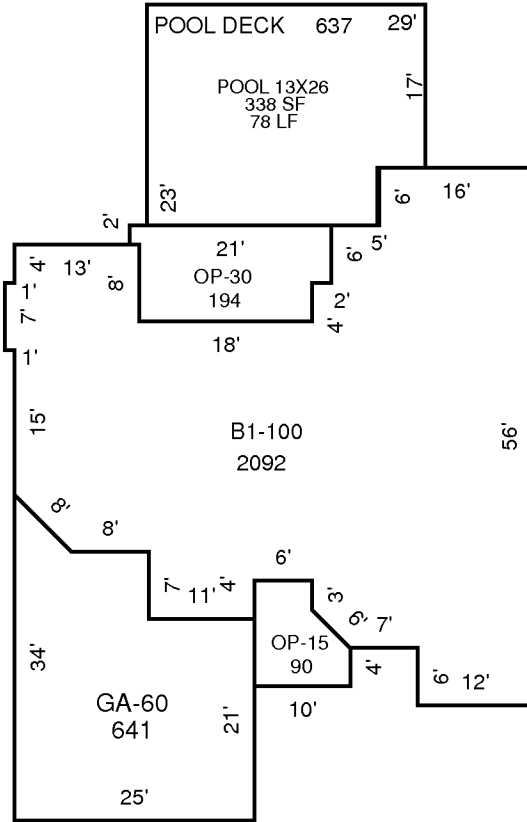

AREA CALCULATIONS

AREA CALCULATIONS SUMMARY

Code	Description	Factor	Net Size	Perimeter	Net Totals
B1	B1-100	1.00	2092	240	2092
GA7	GA-60	1.00	641	114	641
OP4	OP-30	1.00	194	62	194
OP1	OP-15	1.00	90	40	90
PDECK	POOL DECK	1.00	637	104	637

Comment Table 1

--	--

Comment Table 2

Comment Table 3

--	--