

# SKETCH/AREA TABLE ADDENDUM

File No 2950179

Property Address 29-37-32-GU-1225-1

City Palm Bay

County BREVARD

State FL

Zip 32909

Owner

Client Client Address 3182 TELESKA RD. SE

Appraiser Name Tony Cannon

Inspection Date PALM BAY

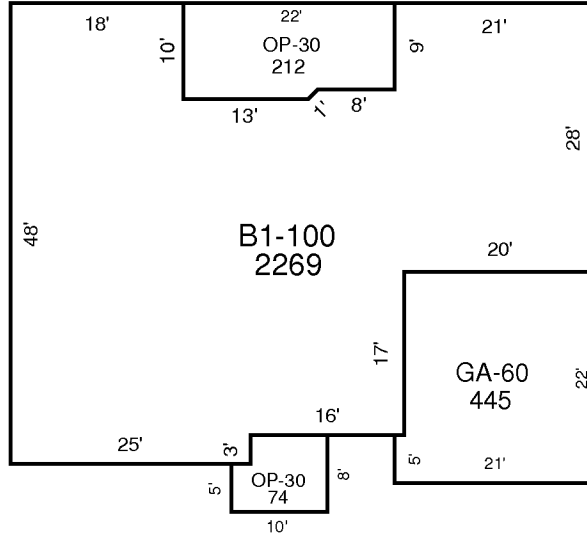

## AREA CALCULATIONS SUMMARY

Code	Description	Factor	Net Size	Perimeter	Net Totals
B1	B1-100	1.00	2269	237	2269
GA7	GA-60	1.00	445	86	445
OP6	OP-30	1.00	74	36	
	OP-30	1.00	212	63	285