

SKETCH/AREA TABLE ADDENDUM

Parcel No 7/25/05

File No 2936425

Property Address 29-37-17-JR-2716-12

City _____ County **BREVARD** State **FL** Zip _____

Owner **PB5003694**

Client _____ Client Address **1484 ASHBORO CIR SE**

Appraiser Name **John Chapman** Inspection Date **Palm Bay**

SUBJECT

IMPROVEMENTS SKETCH

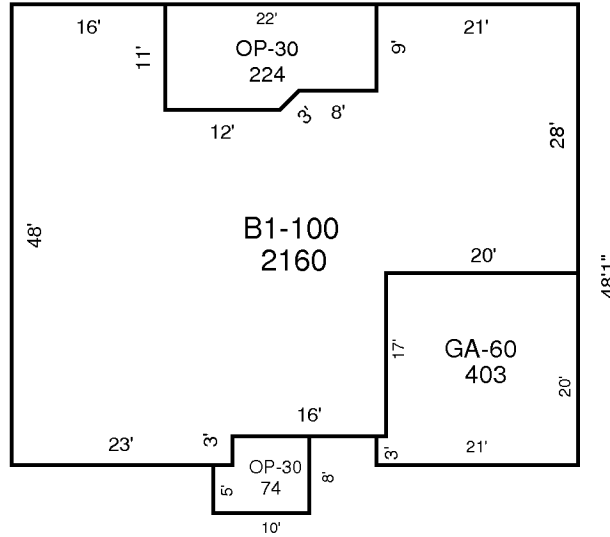

AREA CALCULATIONS

AREA CALCULATIONS SUMMARY

Code	Description	Factor	Net Size	Perimeter	Net Totals
B1	B1-100	1.00	2160	235	2160
GA7	GA-60	1.00	403	82	403
OP4	OP-30	1.00	224	65	224
OP6	OP-30	1.00	74	36	74