

SKETCH/AREA TABLE ADDENDUM

SUBJECT	PARCEL ID 29-37-16-GP-778-15			
	CITY PALM BAY	COUNTY BREVARD	STATE FL	ZIP 32909
	PERMIT # N			
	MARKET AREA 14	ADDRESS 1218 SE PARIS AVE		
	APPRAISER NAME PHK	BRANCH OFFICE PALM BAY		

IMPROVEMENTS SKETCH

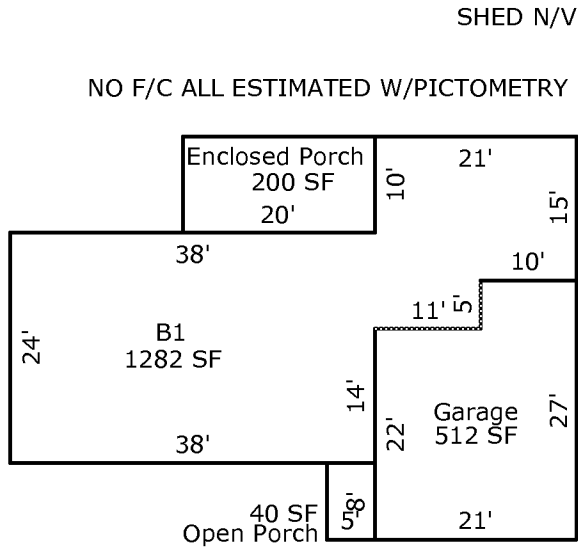

Scale: 1 = 20

AREA CALCULATIONS

AREA CALCULATIONS SUMMARY					
Code	Description	Factor	Net Size	Perimeter	Net Totals
B1	B1	1.00	1282	186	1282
GA	Garage	1.00	512	96	512
EP	Enclosed Porch	1.00	200	60	200
OP	Open Porch	1.00	40	26	40

Comment Table 1	
Comment Table 2	Comment Table 3