

SKETCH/AREA TABLE ADDENDUM

SUBJECT	PARCEL ID 29 3716GP 775. 11.			
	CITY PALM BAY	COUNTY BREVARD	STATE FL	ZIP 32909
	PERMIT # NA			
	MARKET AREA 14	ADDRESS 1360 SE MARINER AVE		
	APPRAISER NAME EWI	BRANCH OFFICE PALM BAY		

EST FROM PICTOMETRY

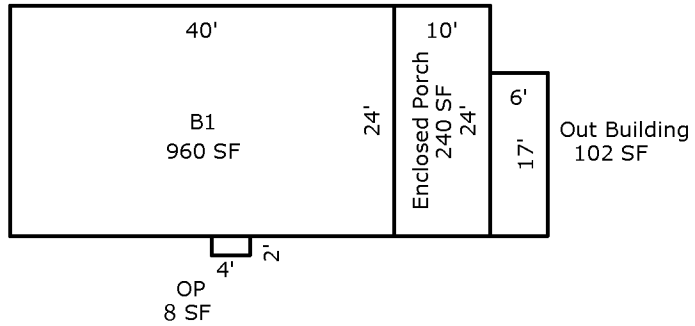
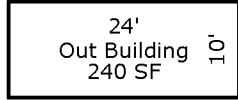

Scale: 1 = 20

AREA CALCULATIONS	AREA CALCULATIONS SUMMARY						Comment Table 1	
	Code	Description	Factor	Net Size	Perimeter	Net Totals		
	B1	B1	1.00	960	128	960		
	EP	Enclosed Porch	1.00	240	68	240		
	OP	OP	1.00	8	12	8		
OBLD	Out Building	1.00	102	46	102			
	Out Building	1.00	240	68	342	Comment Table 2 Comment Table 3		