

SKETCH/AREA TABLE ADDENDUM

File No 2929293

Property Address 29-37-08-GL-458-6

City PALM BAY

County Brevard

State FL

Zip 32909

Owner

Client Client Address 1099 CHEROKEE RD SE

Appraiser Name ewi Inspection Date Palm Bay

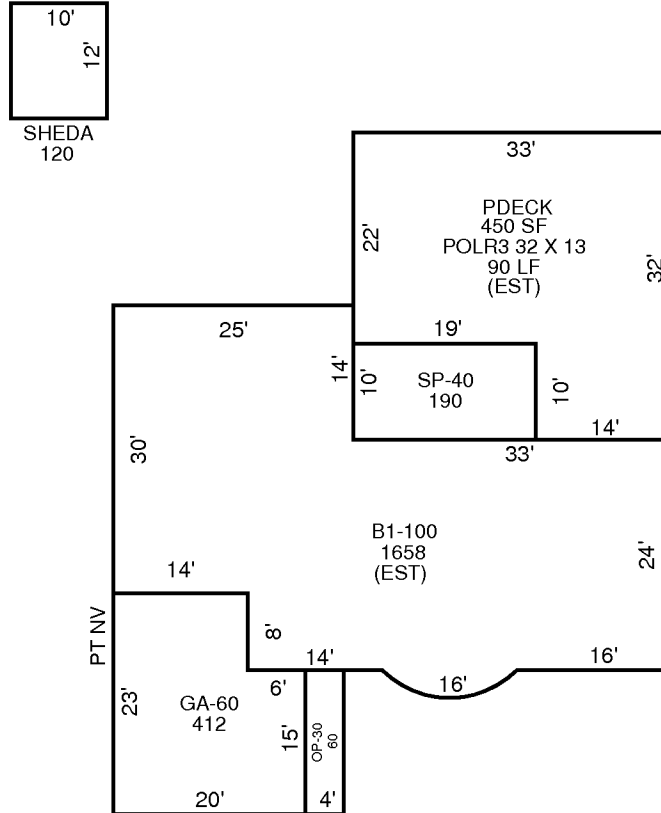

AREA CALCULATIONS SUMMARY

Code	Description	Factor	Net Size	Perimeter	Net Totals
B1	B1-100	1.00	1658	194	1658
GA7	GA-60	1.00	412	86	412
OP4	OP-30	1.00	60	38	60
SP4	SP-40	1.00	190	58	190
OBLDG	SHEDA	1.00	120	44	120
PDECK	PDECK	1.00	866	130	866

Comment Table 1

Comment Table 2

Comment Table 3