

# SKETCH/AREA TABLE ADDENDUM

File No 2927810

Property Address 29-37-07-GN-531-3

City PALM BAY

County BREVARD

State FL

Zip 32909

Owner 04004592

Client

Client Address 981 CARROT AV SE

Appraiser Name EWI

Inspection Date PALM BAY

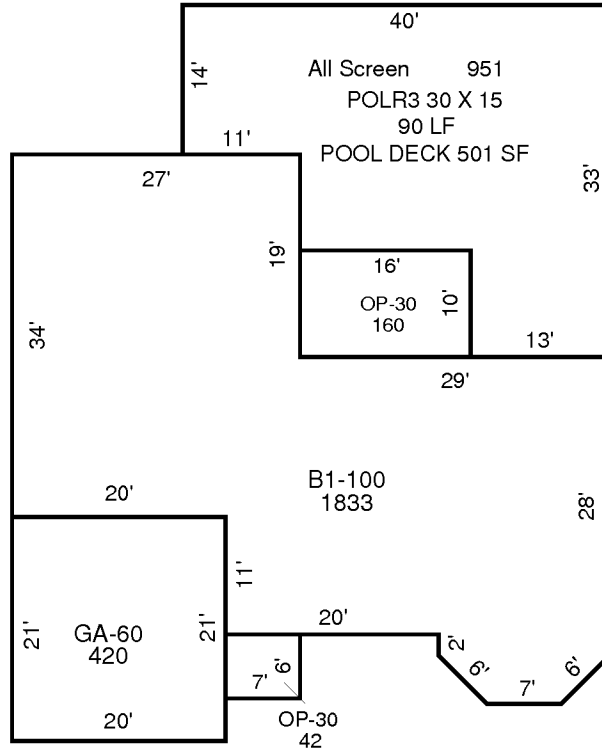

## AREA CALCULATIONS SUMMARY

Code	Description	Factor	Net Size	Perimeter	Net Totals
B1	B1-100	1.00	1833	210	1833
GA7	GA-60	1.00	420	82	420
OP4	OP-30	1.00	160	52	160
OP6	OP-30	1.00	42	26	42
ALSCN	All Screen	1.00	951	146	951

## Comment Table 1

## Comment Table 2

## Comment Table 3