

SKETCH/AREA TABLE ADDENDUM

SUBJECT	PARCEL ID 29-37-06-GK-414-30	COUNTY BREVARD	STATE FL	ZIP 32909
	CITY PALM BAY			
	PERMIT # N			
	MARKET AREA 14	ADDRESS 591 SE BLUEFIELDS ST		
	APPRAISER NAME PHK	BRANCH OFFICE PALM BAY		

IMPROVEMENTS SKETCH

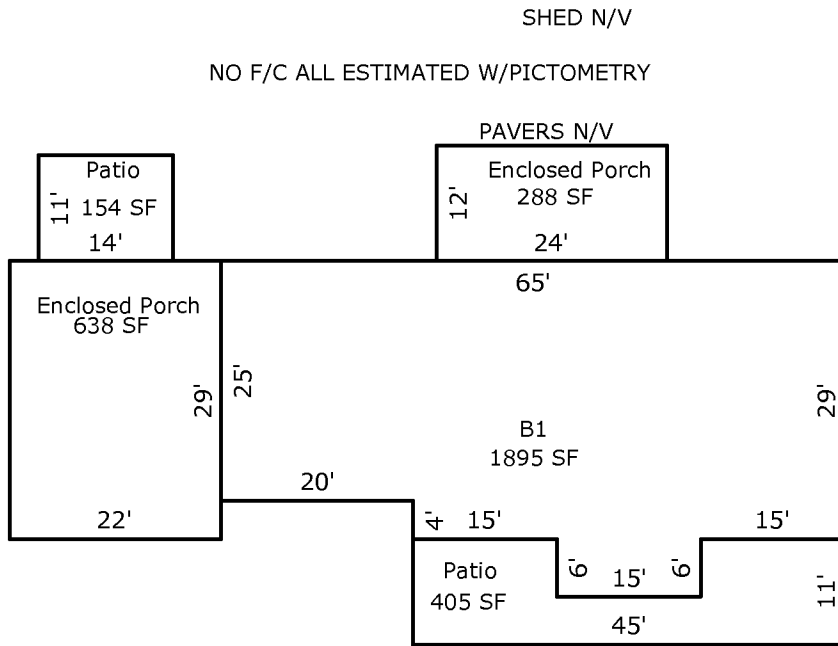

Scale: 1 = 20

AREA CALCULATIONS

AREA CALCULATIONS SUMMARY

Code	Description	Factor	Net Size	Perimeter	Net Totals
B1	B1	1.00	1895	200	1895
EP	Enclosed Porch	1.00	638	102	
	Enclosed Porch	1.00	288	72	926
PT	Patio	1.00	154	50	
	Patio	1.00	405	124	559

Comment Table 1

--	--

Comment Table 2

Comment Table 3

--	--