

SKETCH/AREA TABLE ADDENDUM

Parcel No 6/14/11

File No 2925800

SUBJECT

Property Address 29 3706GK 390. 16.

City PALM BAY

County BREVARD

State FL

Zip 32909

Owner NA

Client 14

Client Address 433 SE HASKELL AVE

Appraiser Name EWI

Inspection Date PALM BAY

IMPROVEMENTS SKETCH

EST FROM PICTOMETRY

Out Building

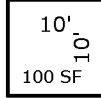

Screen Enclosure

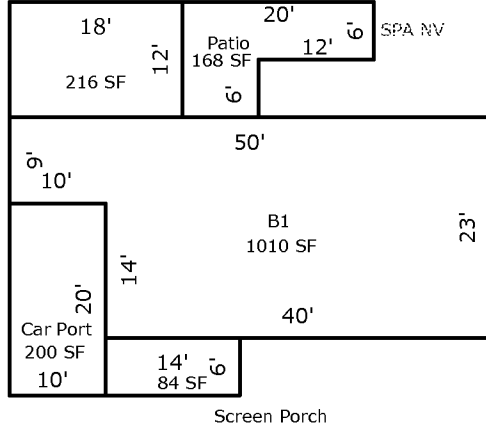

Scale: 1" = 12'

AREA CALCULATIONS

AREA CALCULATIONS SUMMARY

| Code | Description | Factor | Net Size | Perimeter | Net Totals |
|-------|------------------|--------|----------|-----------|------------|
| B1 | B1 | 1.00 | 1010 | 146 | 1010 |
| PT | Patio | 1.00 | 168 | 64 | 168 |
| SP | Screen Porch | 1.00 | 84 | 40 | 84 |
| CP | Car Port | 1.00 | 200 | 60 | 200 |
| OBLD | Out Building | 1.00 | 100 | 40 | 100 |
| SCREN | Screen Enclosure | 1.00 | 216 | 60 | 216 |

Comment Table 1

Comment Table 2

Comment Table 3