

# SKETCH/AREA TABLE ADDENDUM

File No 2913307

SUBJECT

Property Address	29 3625JP 1513 9		
City	County	State	Zip
	BREVARD	FL	
Owner	PB04007225		
Client	Client Address 434 GALLAGHER ST SW		
Appraiser Name	ewi	Inspection Date	Palm Bay

IMPROVEMENTS SKETCH

CANOPY OP NV

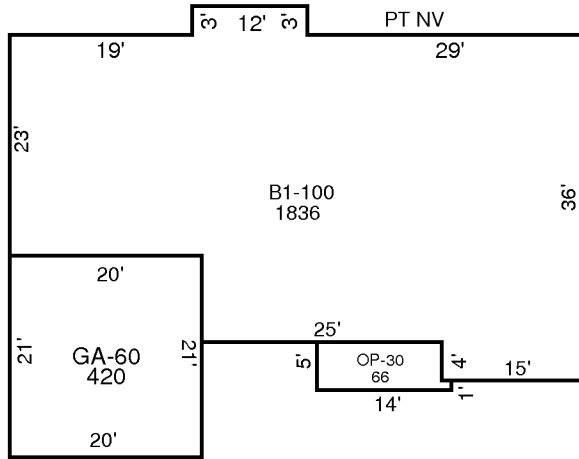

AREA CALCULATIONS

## AREA CALCULATIONS SUMMARY

Code	Description	Factor	Net Size	Perimeter	Net Totals
B1	B1-100	1.00	1836	198	1836
GA7	GA-60	1.00	420	82	420
OP6	OP-30	1.00	66	38	66