

SKETCH/AREA TABLE ADDENDUM

Date 8/26/09

RE # 2906801

SUBJECT

Parcel ID 29-36-12-KK-1634-4

City PALM BAY

County Brevard

State FL

Zip 32908

Permit #

Market Area

Address 961 HANSON AV SW

Appraiser Name GAC

Branch Office PALM BAY

*NO ON SITE MEASUREMENTS CHECKED. PICTOMETRY EST

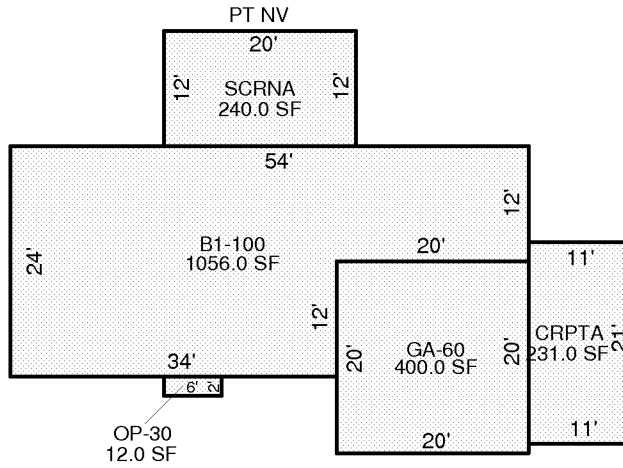

IMPROVEMENTS SKETCH

Scale: 1 = 20

AREA CALCULATIONS

AREA CALCULATIONS SUMMARY

Code	Description	Factor	Net Size	Perimeter	Net Totals
B1	B1-100	1.00	1056.0	156.0	1056.0
OP4	OP-30	1.00	12.0	16.0	12.0
SP4	SCRNA	1.00	240.0	64.0	240.0
CP1	CRPTA	1.00	231.0	64.0	231.0
GA7	GA-60	1.00	400.0	80.0	400.0

Comment Table 1

--	--

Comment Table 2

Comment Table 3

--	--