

# SKETCH/AREA TABLE ADDENDUM

File No 2906768

Property Address **29-36-12-KK-1633-15**

City **PALM BAY**

County **BREVARD**

State **FL**

Zip **32908**

Owner

Client Address **977 HAMMACHER AVE. SW**

Appraiser Name **EWI** Inspection Date **PALM BAY**

Detached Garage  
208

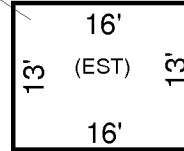

Screen Enclosure  
168

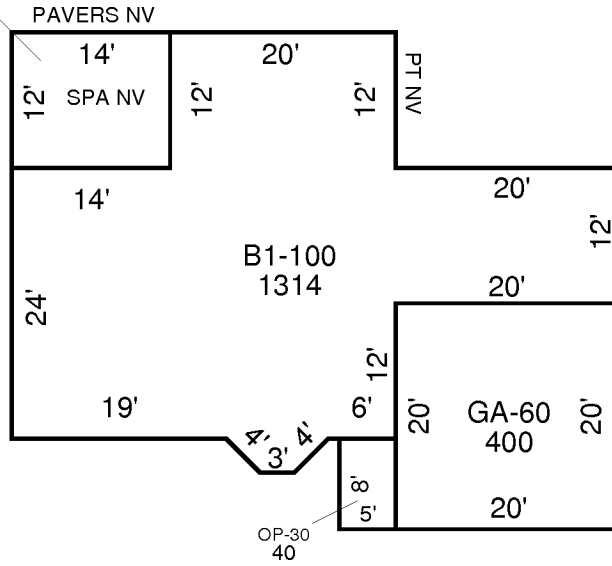

## AREA CALCULATIONS SUMMARY

Code	Description	Factor	Net Size	Perimeter	Net Totals
B1	B1-100	1.00	1314	182	1314
GA7	GA-60	1.00	400	80	400
OP4	OP-30	1.00	40	26	40
GRGD	Detached Garage	1.00	208	58	208
SCREN	Screen Enclosure	1.00	168	52	168

### Comment Table 1

### Comment Table 2

### Comment Table 3