

SKETCH/AREA TABLE ADDENDUM

Parcel No 8/26/08

File No 2905402

Property Address 29 3612KH 1662 24

City PALM BAY

County BREVARD

State FL

Zip 32908

Owner PB08001352

Client 14

Client Address 441 HARRINGTON ST SW

Appraiser Name EWI

Inspection Date PALM BAY

SUBJECT

IMPROVEMENTS SKETCH

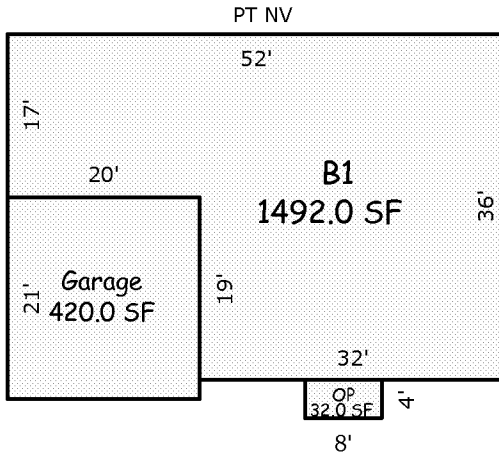

Scale: 1 = 20

AREA CALCULATIONS

AREA CALCULATIONS SUMMARY

Code	Description	Factor	Net Size	Perimeter	Net Totals
B1	B1	1.00	1492.0	176.0	1492.0
GA	Garage	1.00	420.0	82.0	420.0
OP	OP	1.00	32.0	24.0	32.0

Comment Table 1

--

Comment Table 2

Comment Table 3

--	--