

SKETCH/AREA TABLE ADDENDUM

File No 2901953

SUBJECT

Property Address 29-36-02-GI-1010-10

City PALM BAY

County Brevard

State FL

Zip 32908

Owner

Client

Client Address 181 TILE AV SW

Appraiser Name ewi

Inspection Date Palm Bay

IMPROVEMENTS SKETCH

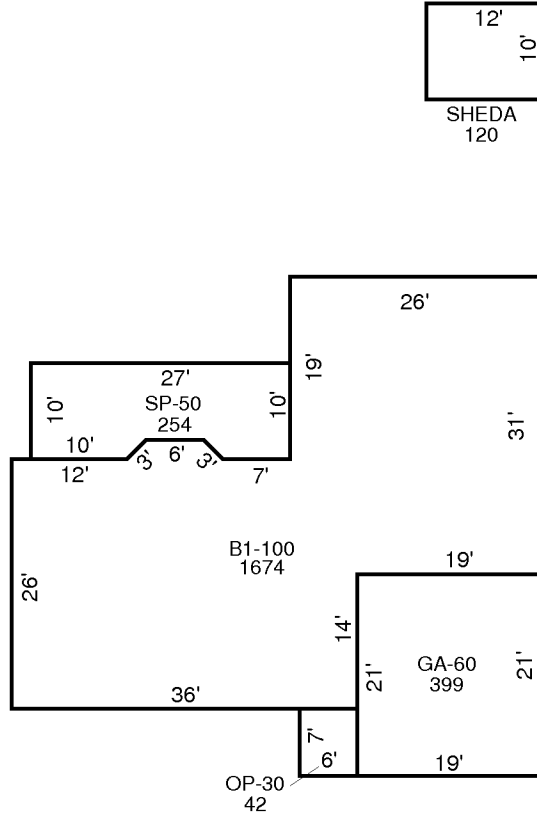

AREA CALCULATIONS

AREA CALCULATIONS SUMMARY

Code	Description	Factor	Net Size	Perimeter	Net Totals
B1	B1-100	1.00	1674	202	1674
GA7	GA-60	1.00	399	80	399
OP4	OP-30	1.00	42	26	42
SP6	SP-50	1.00	254	76	254
OBLDG	OUT BUILDING	1.00	120	44	120

Comment Table 1

--	--

Comment Table 2

Comment Table 3

--	--