

SKETCH/AREA TABLE ADDENDUM

File No 2901851

Property Address 29-36-02-GI-1006-11

City PALM BAY

County BREVARD

State FL

Zip 32908

Owner 0507835

Client

Client Address 256 TRILBY RD SW

Appraiser Name EWI

Inspection Date PALM BAY

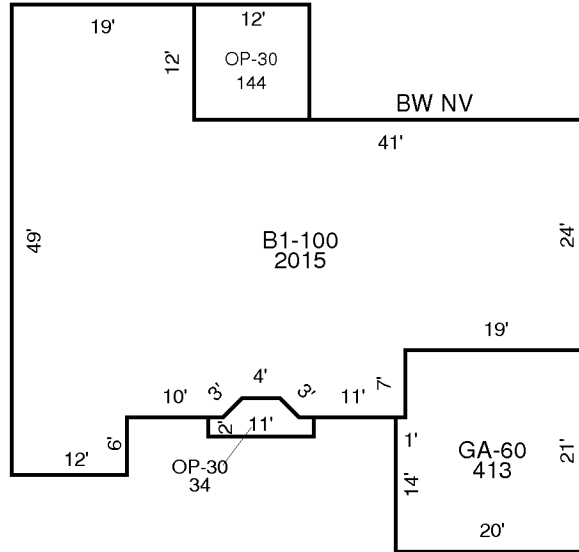

AREA CALCULATIONS SUMMARY

Code	Description	Factor	Net Size	Perimeter	Net Totals
B1	B1-100	1.00	2015	220	2015
GA7	GA-60	1.00	413	82	413
OP6	OP-30	1.00	34	28	
	OP-30	1.00	144	48	178