

SKETCH/AREA TABLE ADDENDUM

File No 2900470

Property Address 29-36-01-25-1068-20

City PALM BAY

County Brevard

State FL

Zip 32908

Owner

Client Client Address 225 SAN LUIS ST SW

Appraiser Name Wayne Ingram

Inspection Date Palm Bay

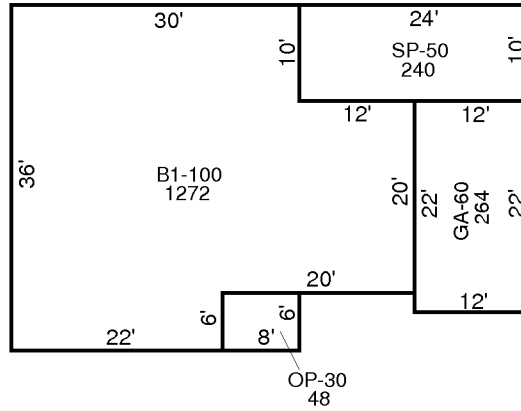

AREA CALCULATIONS SUMMARY

Code	Description	Factor	Net Size	Perimeter	Net Totals
B1	B1-100	1.00	1272	156	1272
GA7	GA-60	1.00	264	68	264
OP4	OP-30	1.00	48	28	48
SP6	SP-50	1.00	240	68	240

Comment Table 1

Comment Table 2

Comment Table 3