

SKETCH/AREA TABLE ADDENDUM

File No 2861497

SUBJECT

Property Address	2837172925				
City	County	Brevard	State	FL	Zip
Owner					
Client	Client Address	1231 Tamango Dr			
Appraiser Name	Paul Knob	Inspection Date	Palm Bay		

IMPROVEMENTS SKETCH

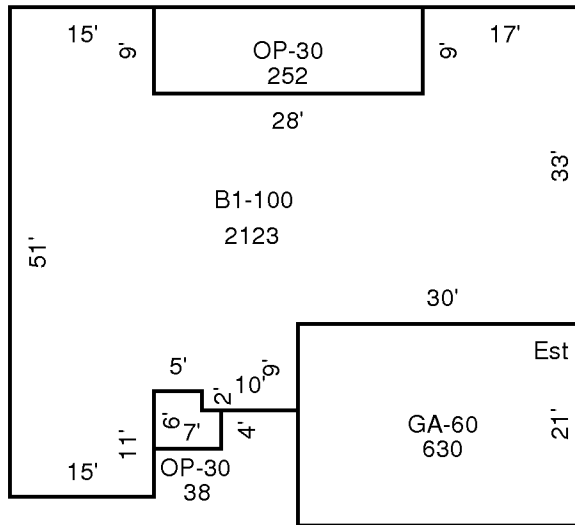

AREA CALCULATIONS

AREA CALCULATIONS SUMMARY					
Code	Description	Factor	Net Size	Perimeter	Net Totals
B1	B1-100	1.00	2123	244	2123
GA7	GA-60	1.00	630	102	630
OP4	OP-30	1.00	38	26	
	OP-30	1.00	252	74	290

Comment Table 1	
Comment Table 2	Comment Table 3