

SKETCH/AREA TABLE ADDENDUM

File No 2860981

SUBJECT

Property Address			
City	County BREVARD	State FL	Zip
Owner 04-731			
Client			
Appraiser Name JOHN T	Inspection Date VIERA		

10/12/2004

IMPROVEMENTS SKETCH

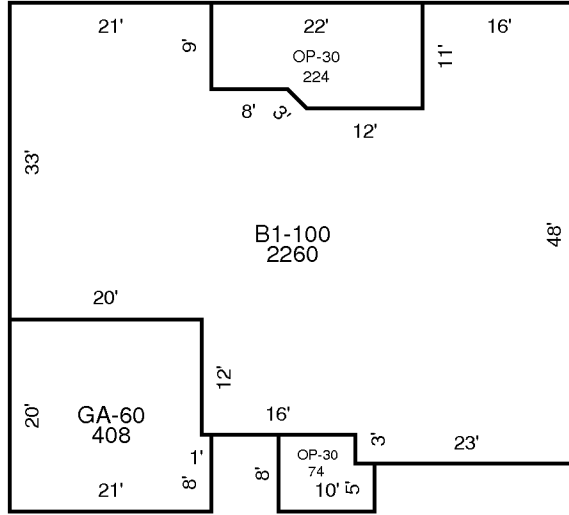

AREA CALCULATIONS

AREA CALCULATIONS SUMMARY

Code	Description	Factor	Net Size	Perimeter	Net Totals
B1	B1-100	1.00	2260	235	2260
GA7	GA-60	1.00	408	82	408
OP6	OP-30	1.00	74	36	
	OP-30	1.00	224	65	298