

SKETCH/AREA TABLE ADDENDUM

File No 2858984

SUBJECT

Property Address	28-37-07-26- -134		
City	W.MELBOURNE	County	BREVARD
		State	FL
Owner	02-969		
Client	Client Address 2362 WOODFIELD CIR		
Appraiser Name	JOHN T	Inspection Date	VIERA

IMPROVEMENTS SKETCH

12/4/2002

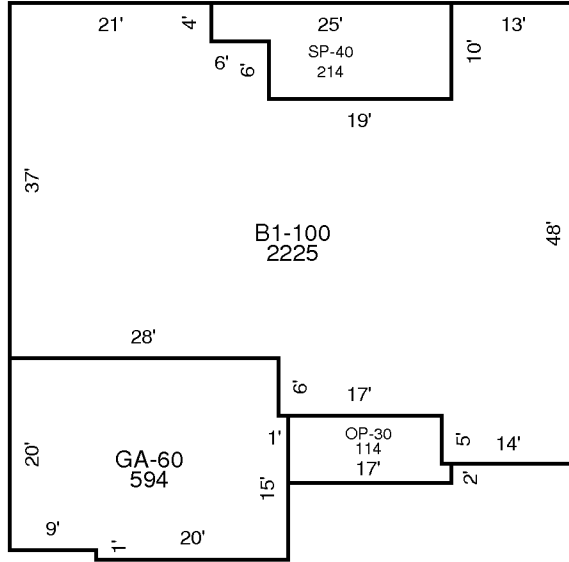

AREA CALCULATIONS

AREA CALCULATIONS SUMMARY

Code	Description	Factor	Net Size	Perimeter	Net Totals
B1	B1-100	1.00	2225	234	2225
GA7	GA-60	1.00	594	100	594
OP6	OP-30	1.00	114	48	114
SP4	SP-40	1.00	214	70	214