

SKETCH/AREA TABLE ADDENDUM

File No 2858954

SUBJECT

Property Address **28-37-07-26- -73**
 City **W.MELBOURNE** County **BREVARD** State **FL** Zip
 Owner **02-1115**
 Client Client Address **1932 WOODFIELD CIR**
 Appraiser Name **JOHN T** Inspection Date **VIERA**

12/4/2002

IMPROVEMENTS SKETCH

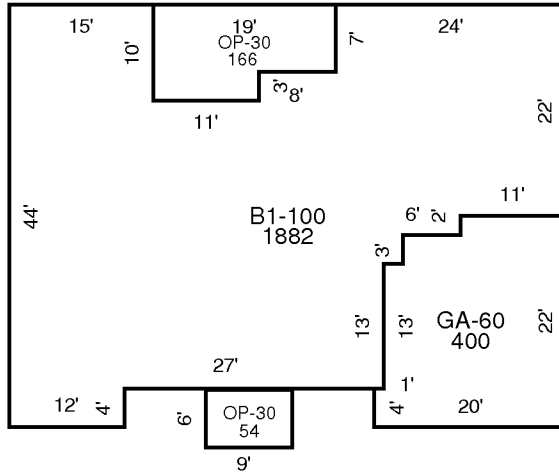

AREA CALCULATIONS

AREA CALCULATIONS SUMMARY

Code	Description	Factor	Net Size	Perimeter	Net Totals
B1	B1-100	1.00	1882	224	1882
GA7	GA-60	1.00	400	84	400
OP6	OP-30	1.00	54	30	
	OP-30	1.00	166	58	220