

# SKETCH/AREA TABLE ADDENDUM

File No 2858947

SUBJECT

Property Address **28-37-07-26- -66**  
 City **W.MELBOURNE** County **BREVARD** State **FL** Zip  
 Owner **MV02-1271**  
 Client Client Address **2523 WOODFIELD CIR**  
 Appraiser Name **JOHN T** Inspection Date **VIERA**

2/14/2003

IMPROVEMENTS SKETCH

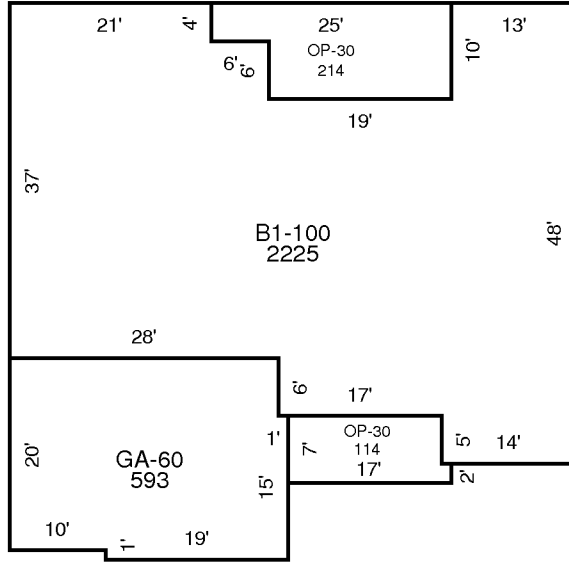

AREA CALCULATIONS

## AREA CALCULATIONS SUMMARY

Code	Description	Factor	Net Size	Perimeter	Net Totals
B1	B1-100	1.00	2225	234	2225
GA7	GA-60	1.00	593	100	593
OP6	OP-30	1.00	114	48	
	OP-30	1.00	214	70	328