

SKETCH/AREA TABLE ADDENDUM

File No 28527570

SUBJECT

Property Address 28-37-07-75-B-48

City MELBOURNE

County BREVARD

State FL

Zip

Owner MV9900024

Client

Client Address 2594 VENTURA CIR

Appraiser Name JOHN T

Inspection Date VIERA

6/24/99

IMPROVEMENTS SKETCH

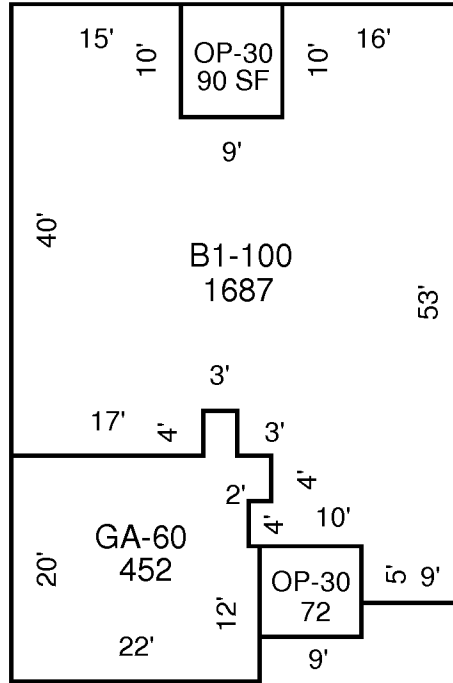

AREA CALCULATIONS

AREA CALCULATIONS SUMMARY

Code	Description	Factor	Net Size	Perimeter	Net Totals
B1	B1-100	1.00	1687	218	1687
GA7	GA-60	1.00	452	96	452
OP4	OP-30	1.00	72	34	
	OP-30	1.00	90	38	162