

SKETCH/AREA TABLE ADDENDUM

RE # 2845818

SUBJECT	PARCEL ID 283734FT167 12			
	CITY PALM BAY	COUNTY BREVARD	STATE FLORIDA	ZIP
	PERMIT #			
	MARKET AREA	ADDRESS 2048 FALLON BLVD NE		
	APPRAISER NAME PHK	BRANCH OFFICE PALM BAY		

IMPROVEMENTS SKETCH

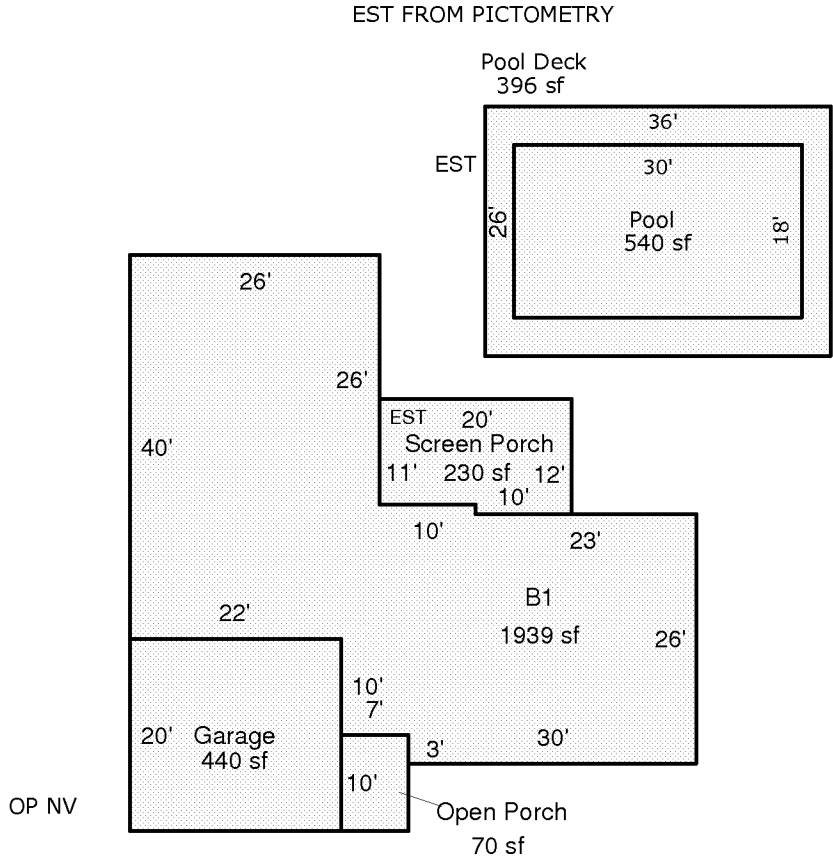

Scale: 1 = 20

AREA CALCULATIONS

AREA CALCULATIONS SUMMARY

Code	Description	Factor	Net Size	Perimeter	Net Totals
B1	B1	1.00	1939	224	1939
GA	Garage	1.00	440	84	440
OP	Open Porch	1.00	70	34	70
SP	Screen Porch	1.00	230	64	230
PDECK	Pool Deck	1.00	396	124	396
POOL	Pool	1.00	540	96	540

Comment Table 1

--	--

Comment Table 2

Comment Table 3

--	--