

# SKETCH/AREA TABLE ADDENDUM

SUBJECT	PARCEL ID <b>2845192</b>		
	CITY	STATE	ZIP
	PERMIT # <b>11/2/11</b>		
	MARKET AREA		
	APPRAISER NAME <b>EWI</b>		

IMPROVEMENTS SKETCH

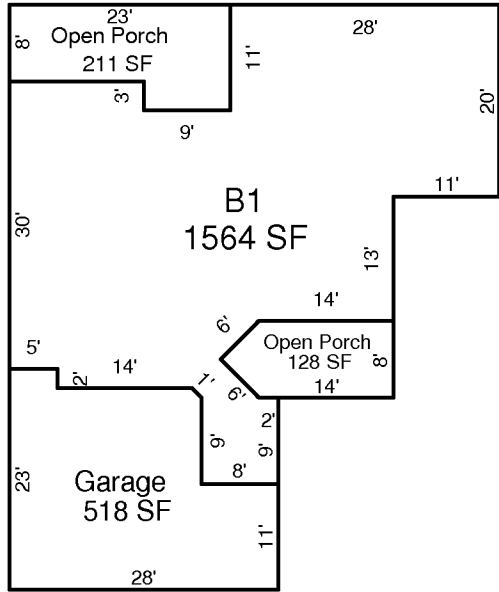

Scale: 1" = 12'

AREA CALCULATIONS

AREA CALCULATIONS SUMMARY					
Code	Description	Factor	Net Size	Perimeter	Net Totals
B1	B1	1.00	1564	215	1564
GA	Garage	1.00	518	101	518
OP	Open Porch	1.00	211	68	
	Open Porch	1.00	128	47	339

Comment Table 1	
Comment Table 2	Comment Table 3