

# SKETCH/AREA TABLE ADDENDUM

SUBJECT	PARCEL ID <b>2840027</b>		
	CITY	STATE	ZIP
	PERMIT # <b>10/18/11</b>		
	MARKET AREA	ADDRESS	
	APPRAISER NAME <b>PHK</b>		

IMPROVEMENTS SKETCH

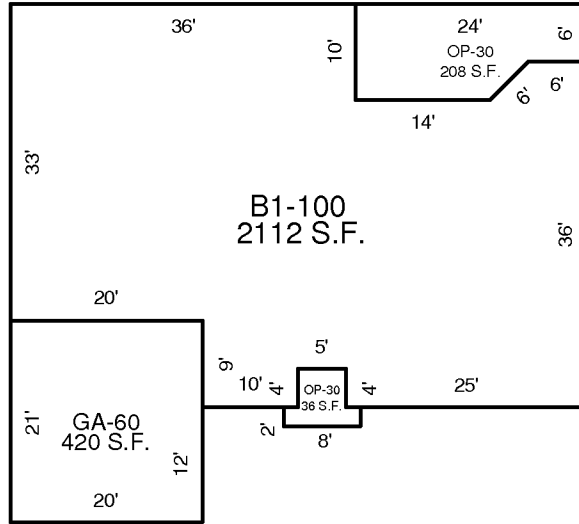

Scale: 1" = 12'

AREA CALCULATIONS

### AREA CALCULATIONS SUMMARY

Code	Description	Factor	Net Size	Perimeter	Net Totals
B1	B1-100	1.00	2112	218	2112
OP 6	OP-30	1.00	36	28	
	OP-30	1.00	208	66	244
GA 7	GA-60	1.00	420	82	420
