

SKETCH/AREA TABLE ADDENDUM

SUBJECT	PARCEL ID 2839994		
	CITY	STATE	ZIP
	PERMIT # 10/18/11		
	MARKET AREA		
	APPRAISER NAME PHK		

IMPROVEMENTS SKETCH

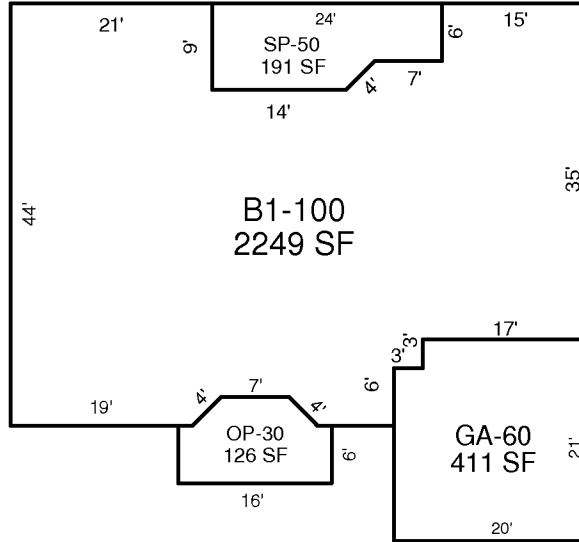

Scale: 1" = 12'

AREA CALCULATIONS

AREA CALCULATIONS SUMMARY

Code	Description	Factor	Net Size	Perimeter	Net Totals
B1	B1-100	1.00	2249	227	2249
OP4	OP-30	1.00	126	46	126
SP6	SP-50	1.00	191	64	191
GA7	GA-60	1.00	411	82	411
