

SKETCH/AREA TABLE ADDENDUM

SUBJECT	PARCEL ID 2837669		
	CITY	STATE	ZIP
	PERMIT # 8/24/11		
	MARKET AREA		
	APPRAISER NAME PHK		

IMPROVEMENTS SKETCH

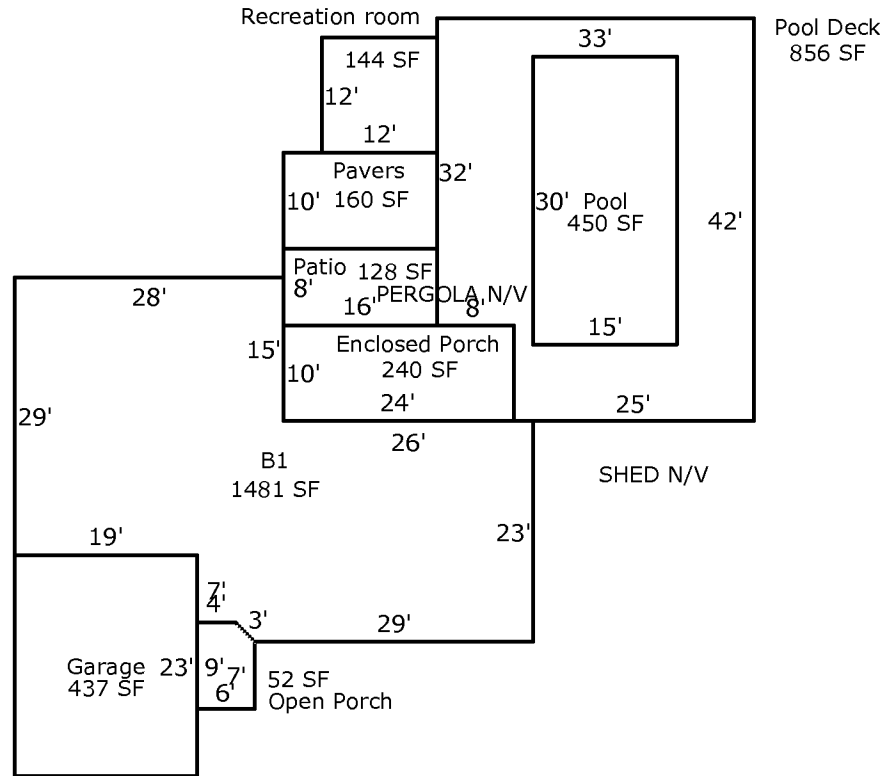

Scale: 1" = 12'

AREA CALCULATIONS

AREA CALCULATIONS SUMMARY

Code	Description	Factor	Net Size	Perimeter	Net Totals
B1	B1	1.00	1481	183	1481
GA	Garage	1.00	437	84	437
EP	Enclosed Porch	1.00	240	68	240
OP	Open Porch	1.00	52	29	52
PT	Patio	1.00	128	48	128
PAVST	Pavers	1.00	160	52	160
PDECK	Pool Deck	1.00	856	150	856
POOL	Pool	1.00	450	90	450
RECRM	Recreation room	1.00	144	48	144

Comment Table 1

Comment Table 2

Comment Table 3