

SKETCH/AREA TABLE ADDENDUM

Parcel No 4-7-08

File No 2828120

Property Address 28 371626 E 6

City MELBOURNE

County BREVARD

State FL

Zip 32901

Owner NONE

Client 13

Client Address 3710 PELICAN POINT WAY

Appraiser Name MAB

Inspection Date VIERA

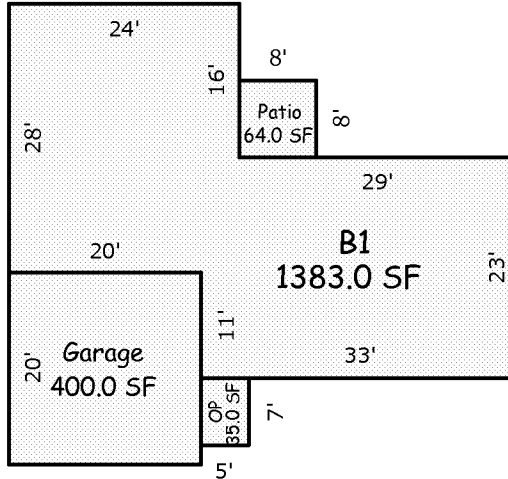

Scale: 1 = 20

AREA CALCULATIONS SUMMARY

Code	Description	Factor	Net Size	Perimeter	Net Totals
B1	B1	1.00	1383.0	184.0	1383.0
GA	Garage	1.00	400.0	80.0	400.0
OP	OP	1.00	35.0	24.0	35.0
PT	Patio	1.00	64.0	32.0	64.0

Comment Table 1

--	--

Comment Table 2

Comment Table 3

--	--

AREA CALCULATIONS

IMPROVEMENTS SKETCH

SUBJECT