

SKETCH/AREA TABLE ADDENDUM

File No 2810337

SUBJECT

Property Address **28-36-27-KO-2330-3**

City **PALM BAY**

County **BREVARD**

State **FL**

Zip

Owner **PB0006052**

Client Client Address **1624 FAIRLIGHT ST NW**

Appraiser Name **JOHN T**

Inspection Date **VIERA**

10/13/2000

IMPROVEMENTS SKETCH

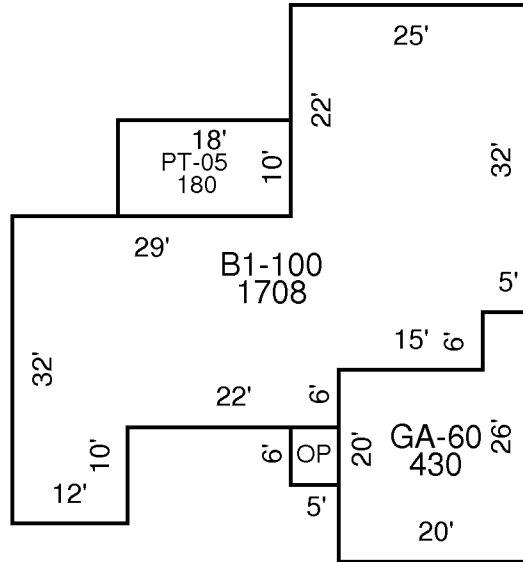

AREA CALCULATIONS

AREA CALCULATIONS SUMMARY

Code	Description	Factor	Net Size	Perimeter	Net Totals
B1	B1-100	1.00	1708	216	1708
GA7	GA-60	1.00	430	92	430
OP4	OP-30	1.00	30	22	30
PT	PT-05	1.00	180	56	180