

SKETCH/AREA TABLE ADDENDUM

Parcel No **2809699**

Property Address **28-36-27-KN-1800-38**

City **Palm Bay**

County **BREVARD**

State **FL**

Zip **32907**

Owner

Client

Client Address **1567 Reed St NV**

Appraiser Name **EWI**

Inspection Date **Palm Bay**

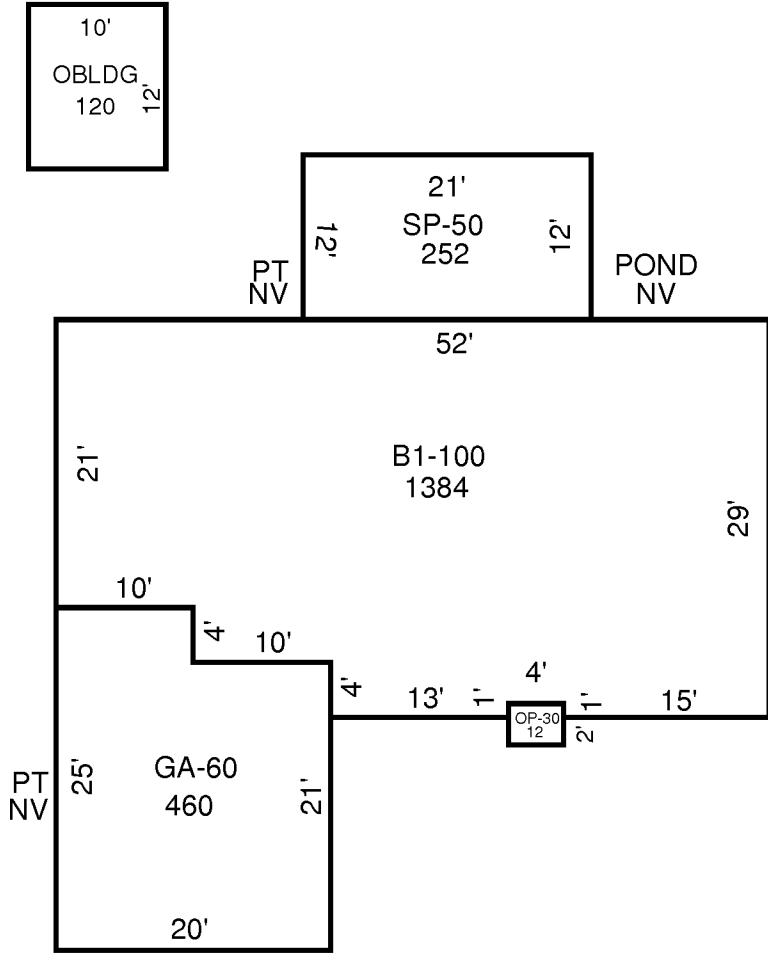

AREA CALCULATIONS SUMMARY

Code	Description	Factor	Net Size	Perimeter	Net Totals
B1	B1-100	1.00	1384	164	1384
GA7	GA-60	1.00	460	90	460
OP4	OP-30	1.00	12	14	12
SP6	SP-50	1.00	252	66	252
OBLDG	OBLDG	1.00	120	44	120

Comment Table 1

--	--

Comment Table 2

Comment Table 3

--	--