

# SKETCH/AREA TABLE ADDENDUM

SUBJECT	PARCEL ID <b>2808342</b>		
	CITY	STATE	ZIP
	PERMIT # <b>8-11-11</b>		
	MARKET AREA		
	APPRAISER NAME <b>MAB</b>		

IMPROVEMENTS SKETCH

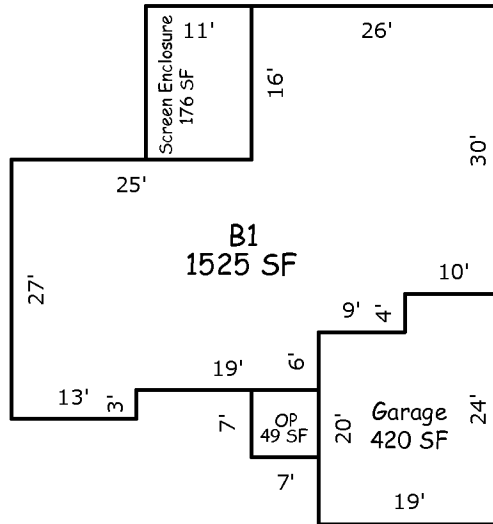

Scale: 1" = 12'

AREA CALCULATIONS

### AREA CALCULATIONS SUMMARY

Code	Description	Factor	Net Size	Perimeter	Net Totals
B1	B1	1.00	1525	188	1525
GA	Garage	1.00	420	86	420
OP	OP	1.00	49	28	49
SCREN	Screen Enclosure	1.00	176	54	176

#### Comment Table 1

--

#### Comment Table 2

#### Comment Table 3

--	--