

SKETCH/AREA TABLE ADDENDUM

File No 27422091

Property Address 27-37-25-60-G-14

City County **BREVARD** State Zip

Owner **SFR 1-8-01 OCO106689 \$182,700**

Client Client Address **306 SOUTHAMPTON DRIVE**

Appraiser Name **GLENN LEGGE** Inspection Date **VIERA (PERMITS)**

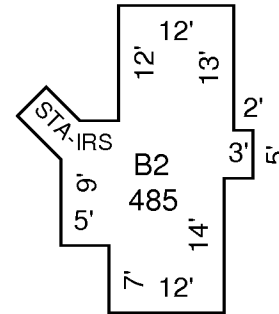
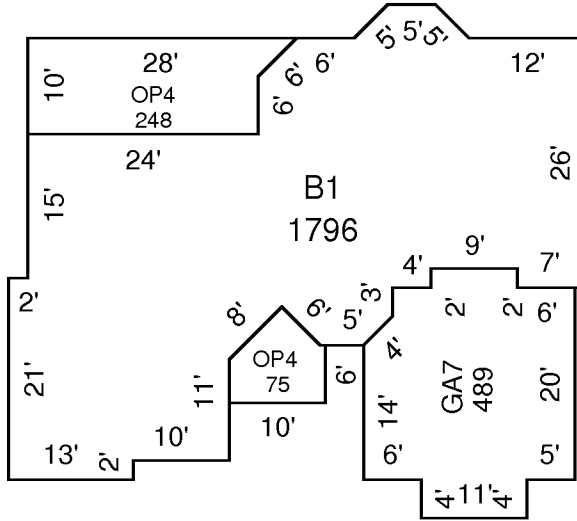

DRAWN: GNL 7-16-01

AREA CALCULATIONS SUMMARY

Code	Description	Factor	Net Size	Perimeter	Net Totals
B1	B1-100	1.00	1796	217	1796
B2	B2-100	1.00	485	114	485
GA7	GA-60	1.00	489	94	489
OP4	OP-30	1.00	75	34	
	OP-30	1.00	248	74	323