

SKETCH/AREA TABLE ADDENDUM

File No 2733203

Property Address 27-37-18-12-A-48

City MELBOURNE

County Brevard

State FL

Zip 32935

Owner

Client Client Address 2035 BLUE RIDGE AV

Appraiser Name Wayne Ingram Inspection Date Palm Bay

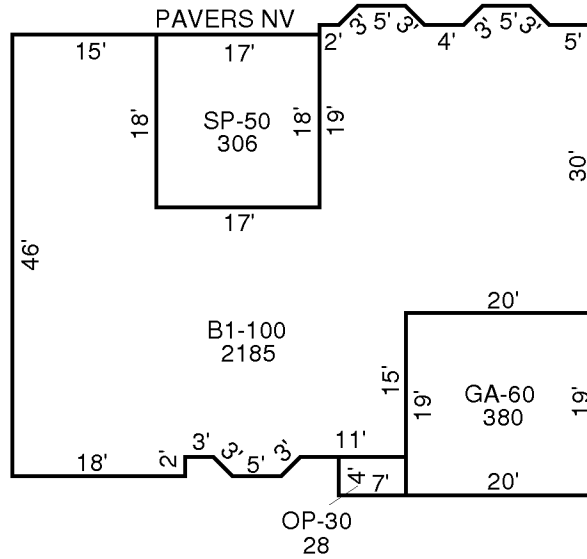

AREA CALCULATIONS SUMMARY

Code	Description	Factor	Net Size	Perimeter	Net Totals
B1	B1-100	1.00	2185	257	2185
GA7	GA-60	1.00	380	78	380
OP4	OP-30	1.00	28	22	28
SP6	SP-50	1.00	306	70	306

Comment Table 1

Comment Table 2

Comment Table 3