

SKETCH/AREA TABLE ADDENDUM

File No 2732542

SUBJECT

Property Address **27-37-18-09-A-16**
 City **MELBOURNE** County **BREVARD** State **FL** Zip
 Owner **9903749,9905170**
 Client Client Address **2251 GRAND TETON BLVD**
 Appraiser Name **JOHN T** Inspection Date **VIERA**

2/9/2000

IMPROVEMENTS SKETCH

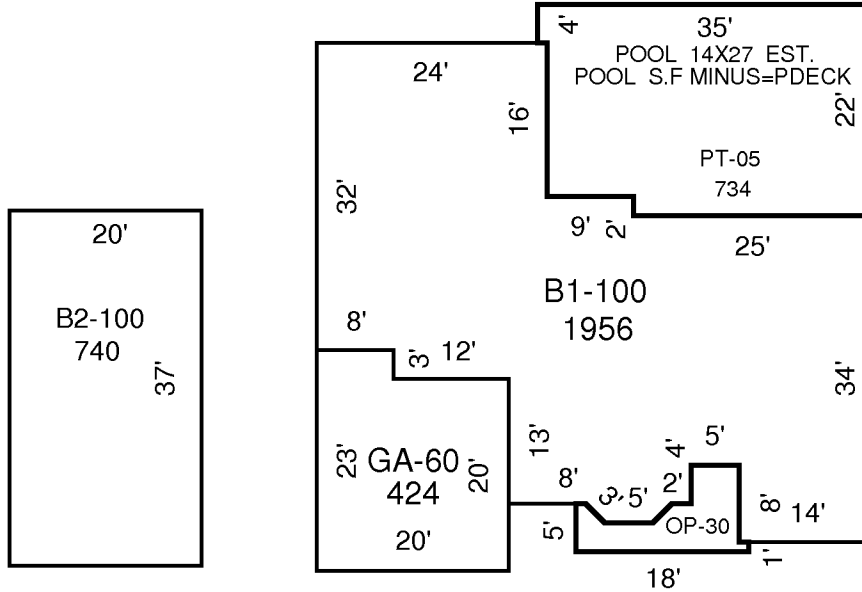

AREA CALCULATIONS

AREA CALCULATIONS SUMMARY

Code	Description	Factor	Net Size	Perimeter	Net Totals
B1	B1-100	1.00	1956	230	1956
B2	B2-100	1.00	740	114	740
GA7	GA-60	1.00	424	86	424
OP4	OP-30	1.00	92	56	92
PT	PT-05	1.00	734	114	734