

# SKETCH/AREA TABLE ADDENDUM

File No 27273711

Property Address 27-37-25-07-B-9

City County BREVARD State Zip

Owner SFR 8-30-02 MO131756 \$227,000

Client Client Address 1715 CANTERBURY DRIVE

Appraiser Name GLENN LEGGE Inspection Date VIERA (PERMITS)

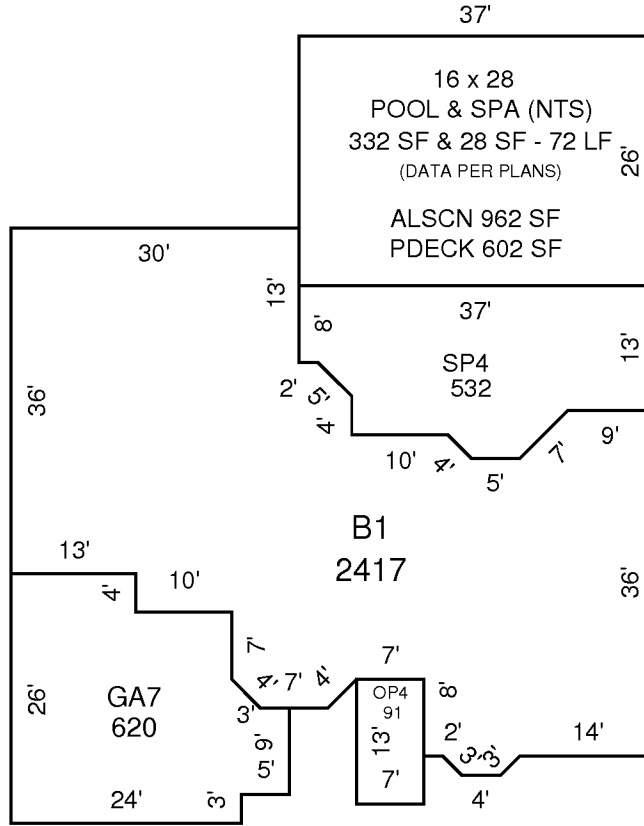

DRAWN: GNL 1-29-03

## AREA CALCULATIONS SUMMARY

Code	Description	Factor	Net Size	Perimeter	Net Totals
B1	B1-100	1.00	2417	252	2417
GA7	GA-60	1.00	620	108	620
OP4	OP-30	1.00	91	40	91
SP4	SP-40	1.00	532	104	532
NON	NON-CALCULATED AREA	1.00	962	126	962