

SKETCH/AREA TABLE ADDENDUM

File No 2723588

Property Address 27-37-20-54-1-13

City MELBOURNE

County Brevard

State FL

Zip 32935

Owner

Client

Client Address 707 IXORA DR

Appraiser Name ewi

Inspection Date Palm Bay

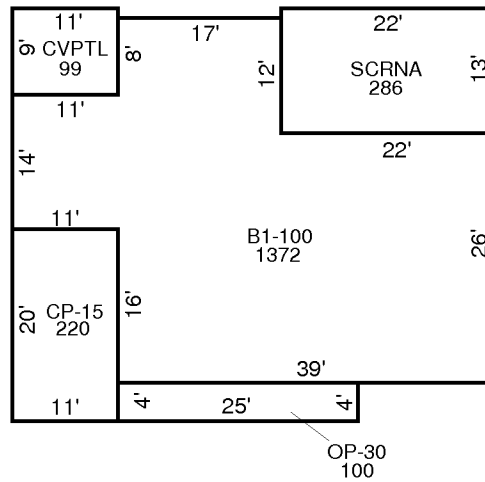
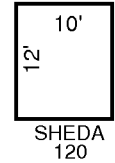

AREA CALCULATIONS SUMMARY

Code	Description	Factor	Net Size	Perimeter	Net Totals
B1	B1-100	1.00	1372	176	1372
OP4	CVPTL	1.00	99	40	
	OP-30	1.00	100	58	199
SP4	SCRNA	1.00	286	70	286
CP1	CP-15	1.00	220	62	220
OBLDG	OUT BUILDING	1.00	120	44	120

Comment Table 1

Comment Table 2

Comment Table 3