

SKETCH/AREA TABLE ADDENDUM

RE # 27012820

SUBJECT	PARCEL ID 27-36-11-27 4	
	CITY	STATE ZIP
	PERMIT # SFR 5-12-98 OCOO72622 \$106,830 11-12-98	
	MARKET AREA	ADDRESS 2661 SHELL WOOD DRIVE
	APPRAISER NAME GLENN LEGGE	BRANCH OFFICE VIERA

IMPROVEMENTS SKETCH

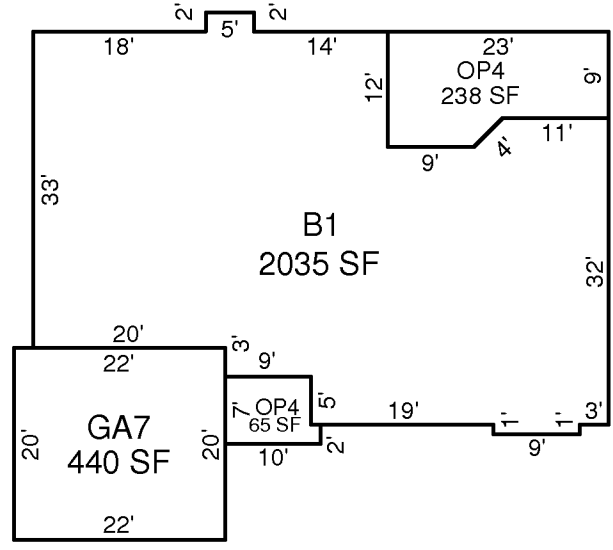

DRAWN: GNL 3-17-99

Scale: 1" = 12'

AREA CALCULATIONS

AREA CALCULATIONS SUMMARY					
Code	Description	Factor	Net Size	Perimeter	Net Totals
B1	B1-100	1.00	2036	212	2036
OP4	OP-30	1.00	65	34	
	OP-30	1.00	239	68	303
GA7	GA-60	1.00	440	84	440
