

SKETCH/AREA TABLE ADDENDUM

SUBJECT	PARCEL ID 2631331		
	CITY	STATE	ZIP
	PERMIT # 9/14/11		
	MARKET AREA		
	APPRAISER NAME GAC	BRANCH OFFICE GAC	

IMPROVEMENTS SKETCH

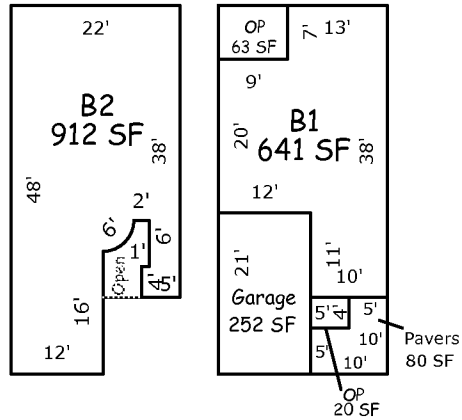
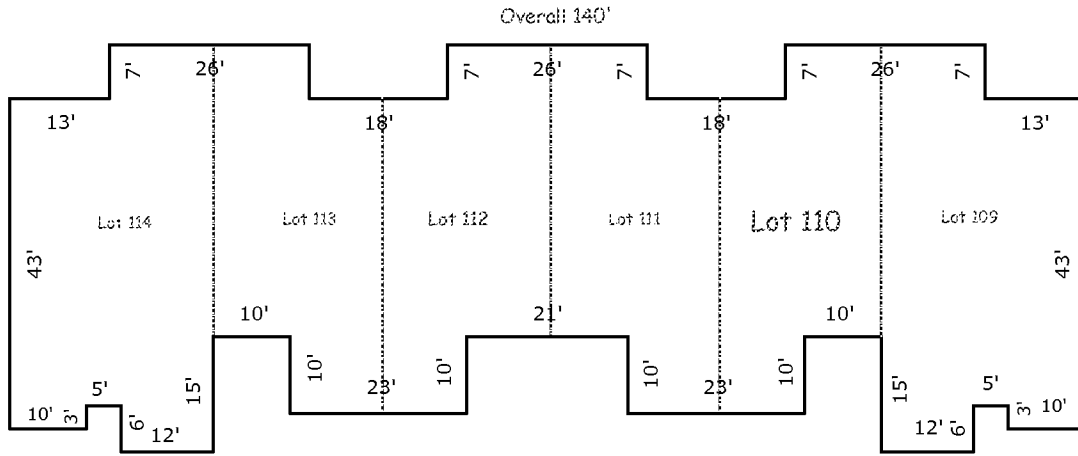

Scale: 1" = 12'

AREA CALCULATIONS

AREA CALCULATIONS SUMMARY

Code	Description	Factor	Net Size	Perimeter	Net Totals
B1	B1	1.00	641	120	641
B2	B2	1.00	912	160	912
GA	Garage	1.00	252	66	252
OP	OP	1.00	20	18	
	OP	1.00	63	32	83
PAVST	Pavers	1.00	80	40	80

Comment Table 1

--	--

Comment Table 2

Comment Table 3

--	--