

# SKETCH/AREA TABLE ADDENDUM

File No **2625066**

SUBJECT	Property Address <b>26-36-26-75-BB-61</b>	County <b>BREVARD</b>	State <b>FL</b>	Zip
	City <b>COUNTY</b>			
	Owner <b>OC0122351</b>			
	Client	Client Address <b>5287 MANSFORD PL</b>		
	Appraiser Name <b>JOHN T</b>	Inspection Date <b>VIERA</b>		

6/12/2002

IMPROVEMENTS SKETCH

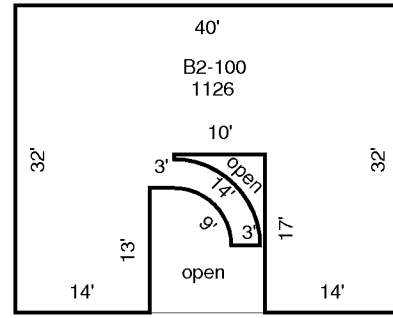
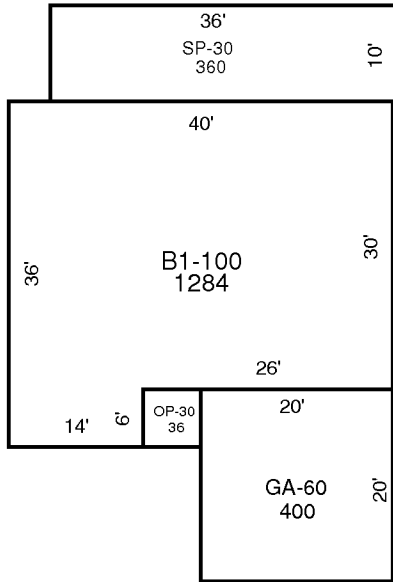

AREA CALCULATIONS

### AREA CALCULATIONS SUMMARY

Code	Description	Factor	Net Size	Perimeter	Net Totals
B1	B1-100	1.00	1284	152	1284
B2	B2-100	1.00	1126	201	1126
GA7	GA-60	1.00	400	80	400
OP4	OP-30	1.00	36	24	36
SP2	SP-30	1.00	360	92	360
