

SKETCH/AREA TABLE ADDENDUM

File No 26250081

Property Address 26-36-26-50-FF-4

City County **BREVARD** State Zip

Owner **SFR 10-31-02 MO135201 \$150,000**

Client Client Address **4008 CHASTAIN DRIVE**

Appraiser Name **GLENN LEGGE** Inspection Date **VIERA (PERMITS)**

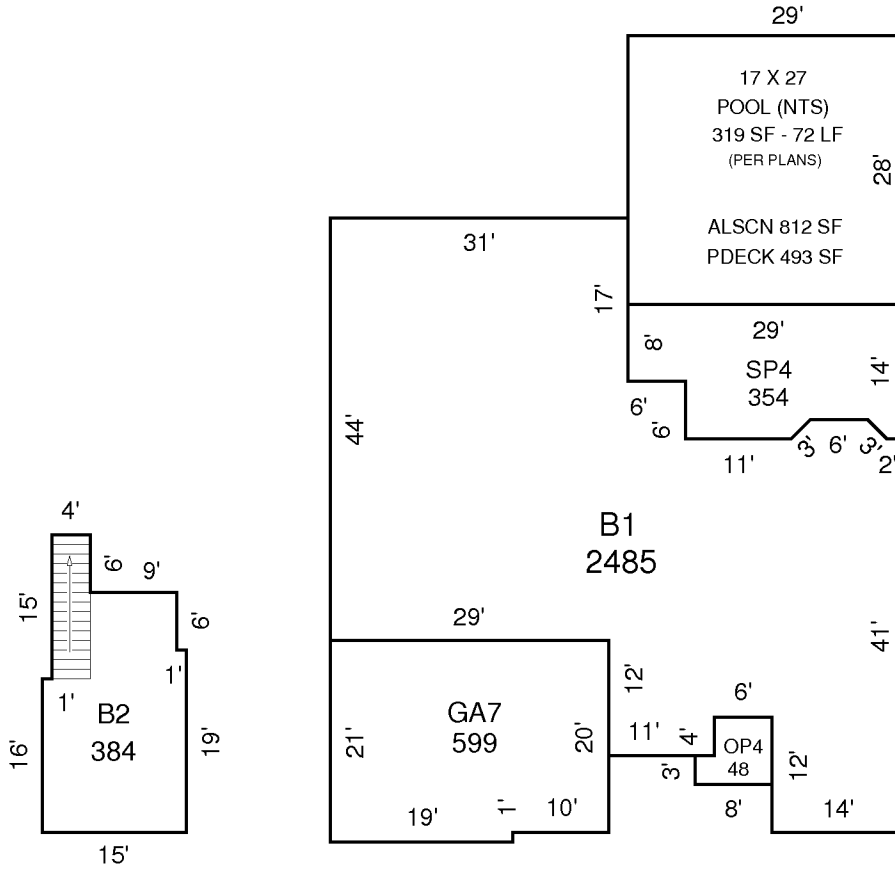

DRAWN: GNL 3-13-03

AREA CALCULATIONS SUMMARY

Code	Description	Factor	Net Size	Perimeter	Net Totals
B1	B1-100	1.00	2485	258	2485
B2	B2-100	1.00	384	92	384
GA7	GA-60	1.00	599	100	599
OP4	OP-30	1.00	48	30	48
SP4	SP-40	1.00	354	88	354
NON	NON-CALCULATED AREA	1.00	812	114	812