

SKETCH/AREA TABLE ADDENDUM

File No 26248061

SUBJECT

Property Address	26-36-25-53-Q-9		
City	County	BREVARD	State
Owner	SFR 10-1-02 MO134524 \$209,915		
Client	Client Address 4747 ALAMANDA DRIVE		
Appraiser Name	GLENN LEGGE	Inspection Date	VIERA (PERMITS)

IMPROVEMENTS SKETCH

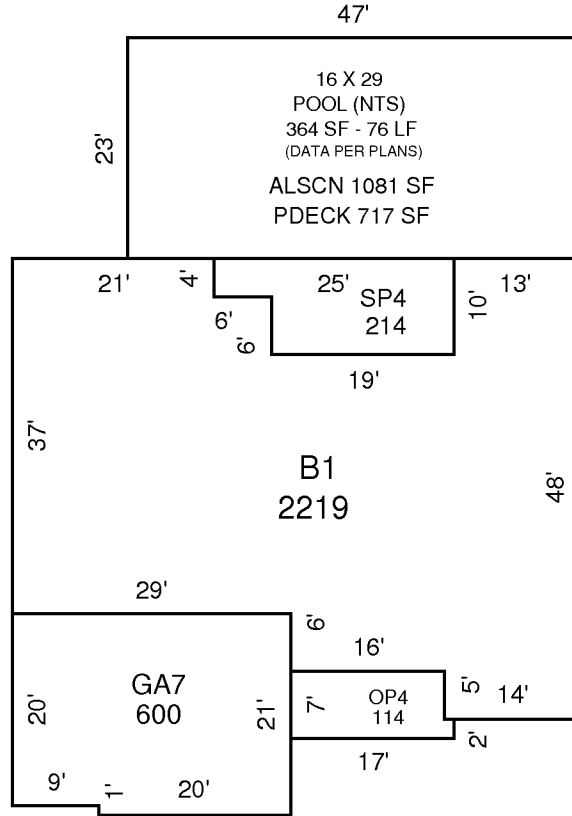

DRAWN: GNL 2-25-03

AREA CALCULATIONS

AREA CALCULATIONS SUMMARY

Code	Description	Factor	Net Size	Perimeter	Net Totals
B1	B1-100	1.00	2219	234	2219
GA7	GA-60	1.00	600	100	600
OP4	OP-30	1.00	114	48	114
SP4	SP-40	1.00	214	70	214
NON	NON-CALCULATED AREA	1.00	1081	140	1081