

SKETCH/AREA TABLE ADDENDUM

File No 26233351

SUBJECT

Property Address	26-36-03-RR-A-7		
City	County	BREVARD	State
Owner	SFR 2-16-01 OCO108310 \$90,000		
Client	Client Address 1956 CRANE CREEK BLVD		
Appraiser Name	GLENN LEGGE	Inspection Date	VIERA (PERMITS)

IMPROVEMENTS SKETCH

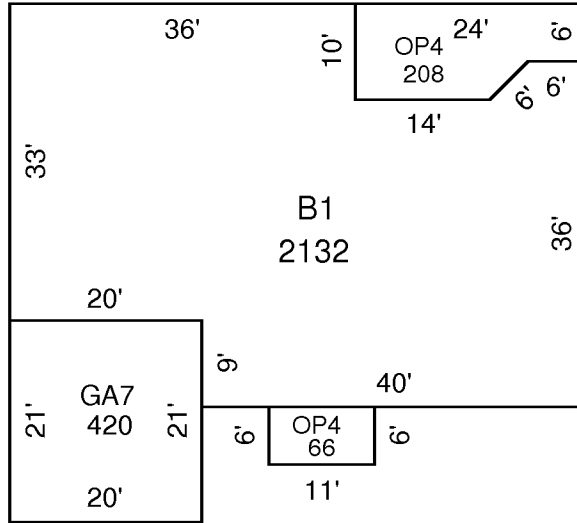

DRAWN: GNL 6-11-01

AREA CALCULATIONS

AREA CALCULATIONS SUMMARY

Code	Description	Factor	Net Size	Perimeter	Net Totals
B1	B1-100	1.00	2132	210	2132
GA7	GA-60	1.00	420	82	420
OP4	OP-30	1.00	66	34	
	OP-30	1.00	208	66	274