

SKETCH/AREA TABLE ADDENDUM

SUBJECT	Property Address		
	City	State	Zip
	Owner		
	Client		
	Appraiser Name		

IMPROVEMENTS SKETCH

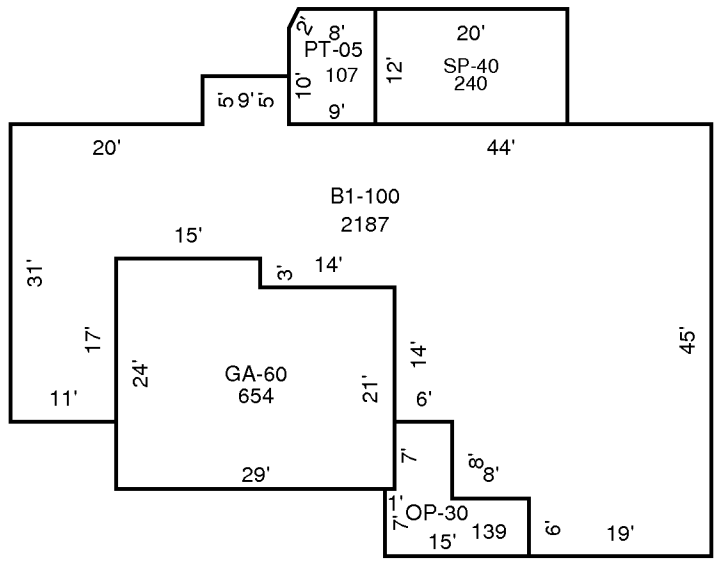

AREA CALCULATIONS

AREA CALCULATIONS SUMMARY					
Code	Description	Factor	Net Size	Perimeter	Net Totals
B1	B1-100	1.00	2187	280	2187
GA7	GA-60	1.00	654	106	654
OP4	OP-30	1.00	139	58	139
PT	PT-05	1.00	107	41	107
SP4	SP-40	1.00	240	64	240

Comment Table 1	
Comment Table 2	Comment Table 3