

SKETCH/AREA TABLE ADDENDUM

Parcel No 5/22/08

File No 2613202

Property Address 26-37-35-02-17-8

City SATELLITE BCH

County Brevard

State FL

Zip 32937

Owner N

Client 52

Client Address 515 WILSON AV

Appraiser Name PHK

Inspection Date PALM BAY

SUBJECT

IMPROVEMENTS SKETCH

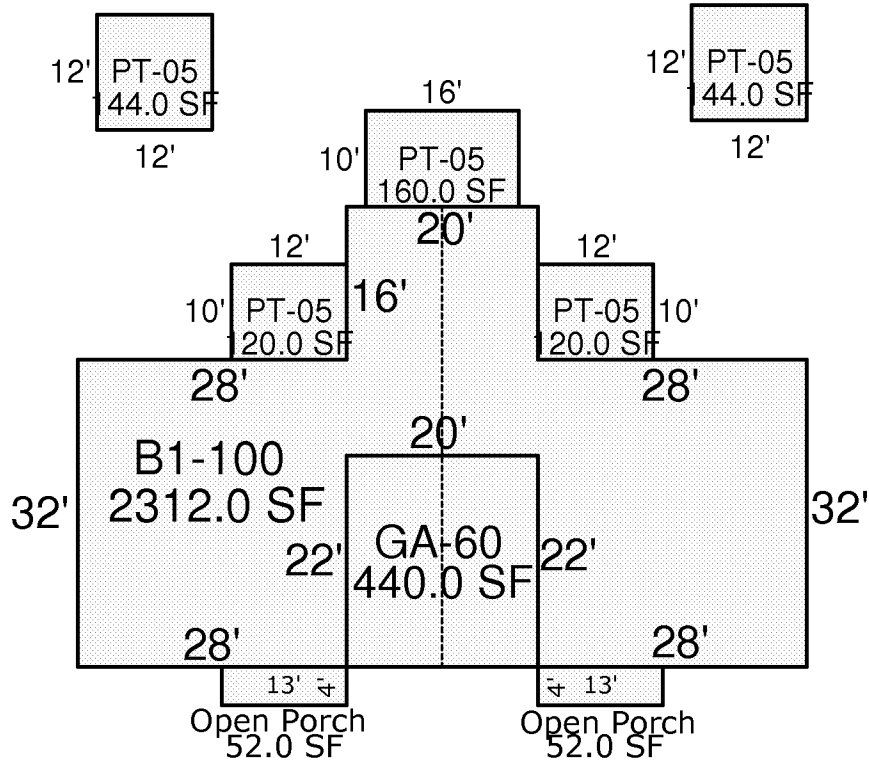

Scale: 1 = 20

AREA CALCULATIONS

AREA CALCULATIONS SUMMARY

Code	Description	Factor	Net Size	Perimeter	Net Totals
B1	B1-100	1.00	2312.0	292.0	2312.0
OP	Open Porch	1.00	52.0	34.0	
	Open Porch	1.00	52.0	34.0	104.0
PT	PT-05	1.00	120.0	44.0	
	PT-05	1.00	120.0	44.0	
	PT-05	1.00	160.0	52.0	
	PT-05	1.00	144.0	48.0	
	PT-05	1.00	144.0	48.0	688.0
GA7	GA-60	1.00	440.0	84.0	440.0
