

SKETCH/AREA TABLE ADDENDUM

RE # 2608878

SUBJECT	PARCEL ID 26 3727W 57	CITY satellite bch	COUNTY Brevard	STATE FL	ZIP
	PERMIT #				
	MARKET AREA	ADDRESS 456 BRIDGETOWN CT			
	APPRAISER NAME Juan Arboleda	BRANCH OFFICE Merritt Island			

DOCK 394 SF
DROOF 375 SF EST. EST FROM PICTOMETRY

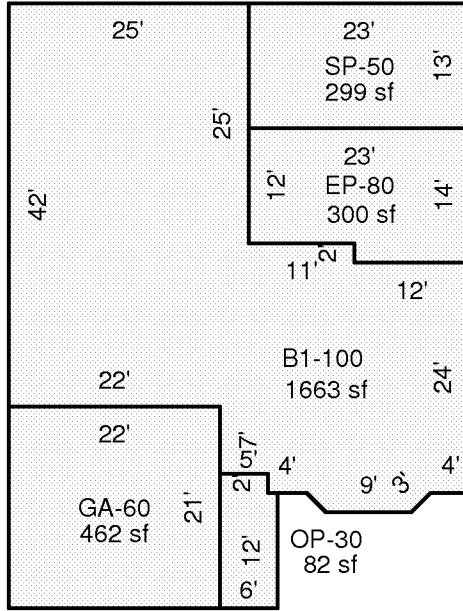

Scale: 1 = 20

AREA CALCULATIONS	AREA CALCULATIONS SUMMARY						Comment Table 1	
	Code	Description	Factor	Net Size	Perimeter	Net Totals		
	B1	B1-100	1.00	1663	200	1663		
	OP4	OP-30	1.00	82	40	82		
	EP5	EP-80	1.00	300	74	300		
SP6	SP-50	1.00	299	72	299			
GA7	GA-60	1.00	462	86	462			
							Comment Table 2	Comment Table 3